



SERIES 301/311 Wafer/Lug
2" - 20" (50mm-500mm)

BUTTERFLY VALVES

RESILIENT SEATED

SERIES 301

2"-20" (50mm-500mm)

Skywell is proud to offer a high quality line of butterfly valves to meet the requirements of today's market. Combining years of field application experience, research and development, Skywell has designed many unique features in the Series 301/311 not previously available. The results are longer service life, greater reliability, ease of parts replacement and interchangeability of components.

DISC AND STEM CONNECTION

(A) Features a high-strength through stem design. The close tolerance, double "D" connection that drives the valve disc is an exclusive feature of the Skywell valve. It eliminates stem retention components being exposed to the line media, such as disc screws and taper pins, which commonly result in leak paths, corrosion, and vibration failures. Disc screws or taper pins, due to wear and corrosion, often

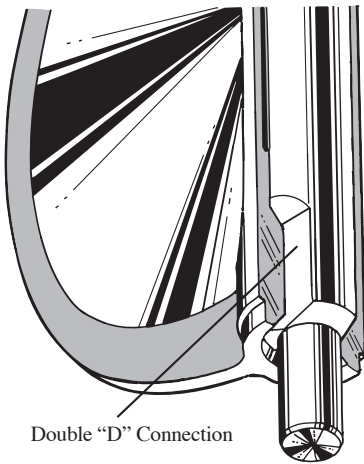

require difficult machining for disassembly. Disassembly of the Skywell stem is just a matter of pulling the stem out of the disc. Without fasteners obstructing the line flow, the Series 301/311 C_v values are higher than many other valves, turbulence is reduced, and pressure recovery is increased. The stem ends and top mounting flange are standardized for interchangeability with Skywell actuators.

DISC (B) Casting is spherically machined and hand polished to provide a bubble-tight shut off, minimum torque, and longer seat life. The disc O.D. clearance is designed to work with all standard piping.



STEM BUSHING (D)

Non-corrosive, heavy duty acetal bushing absorbs actuator side thrusts.

STEM SEAL (E)

Double "U" cup seal design is self-adjusting and gives positive sealing in both directions. Prevents external substances from entering the stem bore.

NECK (F) Extended neck length allows for 2" of piping insulation and is easily accessible for mounting actuators.

PRIMARY AND SECONDARY SEALS (G)

The Primary Seal is achieved by an interference fit of the molded seat flat with the disc hub. The Secondary Seal is created because the stem diameter is greater than the diameter of the seat stem hole. These seals prevent line media from coming in contact with the stem or body.

STEM RETAINING ASSEMBLY (C)

The stem is retained in the body by means of a unique Stainless Steel "Spirolox" retaining ring, a thrust washer and two C-rings, manufactured from brass as standard, stainless steel upon request. The retaining ring may be easily removed with a standard hand tool. The stem retaining assembly prevents unintentional removal of the stem during field service.

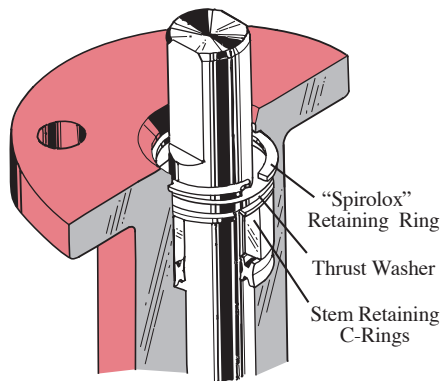

SKYWELL UNIQUE SEAT DESIGN (H)

One of the valve's key elements is Skywell unique **tongue and groove** seat design. This resilient seat features lower torque than many valves on the market today and provides complete isolation of flowing media from the body. The tongue-and-groove seat to body retention method is superior to traditional designs, making field replacement simple and fast. The seat is specifically designed to seal with slip-on or weld-neck flanges. The seat features a molded O-ring which eliminates the use of flange gaskets. An important maintenance feature is

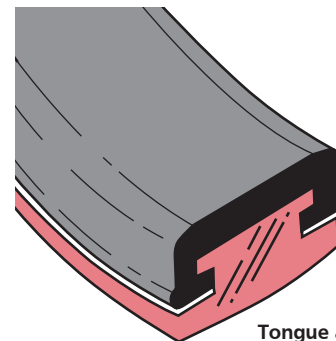

that all resilient seats for Skywell butterfly valves Series 201, 211, 301 and 341 are completely interchangeable.

ACTUATOR MOUNTING FLANGE AND STEM CONNECTION (I)

Universally designed to ISO 5211 for direct mounting of Skywell power actuators and manual operators.

FLANGE LOCATING HOLES (J)

Provide quick and proper alignment during installation.

BODY (K) One-piece wafer or lug style. Polyester coating for excellent corrosion resistance. Skywell valve bodies meet ANSI 150 pressure ratings for hydrostatic shell test requirements.

DESIGN FEATURES

Skywell Series 301 valve is a wafer version with flange locating holes, and the Series 311 is the companion lug version for dead-end service and other flange requirements. All Skywell valves are tested to 110% of full pressure rating before shipment. A major design advantage of Skywell valve product lines is international compatibility. The same valve is compatible with most world flange standards – ANSI Class 125/150, BS 10 Tables D and E, BS 4504 NP 10/16, DIN ND 10/16, AS 2129 and JIS 10. In addition the valves are designed to comply with ISO 5752 face-to-face and ISO 5211 actuator mounting flanges. Therefore, one valve design can be used in many different world markets.

Due to a modular concept of design, all Skywell handles, manual gear operators and pneumatic and electric actuators mount directly to Skywell. No brackets or adapters are required.



Skywell interchange ability and compatibility offers you the best in uniformity of product line and low-cost performance in the industry today.

POLYESTER COATING CORROSION PROTECTION

Skywell standard product offers valve bodies with a polyester coating, providing excellent corrosion and wear resistance to the valve's surface. The Skywell polyester coating is a hard, gloss red finish. Chemical Resistance – resists a broad range of chemicals including: dilute aqueous acids and alkalis, petroleum solvents, alcohols, greases and oils. Offers outstanding resistance to humidity and water. Weatherability – outdoor tested resistant to ultra-violet radiation. Abrasion Resistance – excellent resistance to abrasion. Impact Resistance – withstands impact without chipping or cracking.

NYLON 11 COATING

Optionally available for valve bodies where outstanding protection and performance is needed. A thermoplastic produced from a vegetable base, this coating is inert to fungus growth and molds. Nylon 11 is **USDA Approved** as well as certified to ANSI/NSF 61 for water service. Corrosion Resistance – superior resistance to a broad range of chemical environments. Salt spray tested in excess of 2,000 hours and seawater immersion tested for over 10 years without corrosion to metal substrates. Nylon 11 features a very low coefficient of friction and excellent resistance to impact and ultra-violet radiation.

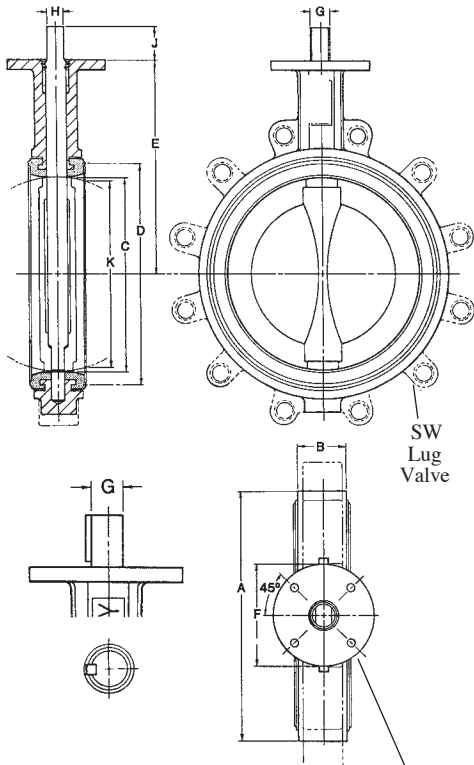

DIMENSIONS SERIES 301 Wafer

Valve Size	ins	mm	A	B	C	D	E	F	Mounting Flange Drig.			G	H	J	K
									BC	No. Holes	Hole Dia.				
2	50	3.69	1.62	2.00	2.84	5.50	3.54	2.76	4	.39	.55	.39	1.25	1.32	
2 1/2	65	4.19	1.75	2.50	3.34	6.00	3.54	2.76	4	.39	.55	.39	1.25	1.91	
3	80	4.88	1.75	3.00	4.03	6.25	3.54	2.76	4	.39	.55	.39	1.25	2.55	
4	100	6.06	2.00	4.00	5.16	7.00	3.54	2.76	4	.39	.63	.43	1.25	3.57	
5	125	7.06	2.12	5.00	6.16	7.50	3.54	2.76	4	.39	.75	.51	1.25	4.63	
6	150	8.12	2.12	5.75	7.02	8.00	3.54	2.76	4	.39	.75	.51	1.25	5.45	
8	200	10.50	2.50	7.75	9.47	9.50	5.91	4.92	4	.57	.87	.63	1.25	7.45	
10	250	12.75	2.50	9.75	11.47	10.75	5.91	4.92	4	.57	1.18	.87	2.00	9.53	
12	300	14.88	3.00	11.75	13.47	12.25	5.91	4.92	4	.57	1.18	.87	2.00	11.47	

SERIES 311 Lug

Valve Size	ins	mm	A	B	C	D	E	F	Mounting Flange Drig.			G	J	KEY SIZE	K	Lug Bolting Data		
									BC	No. Holes	Hole Dia.					BC	No. Holes	Threads UNC-2B
14	350	17.05	3.00	13.25	15.28	13.62	5.91	4.92	4	.57	1.38	2.00	.39x.39	13.04	18.75	12	1-8	
16	400	19.21	4.00	15.25	17.41	14.75	5.91	4.92	4	.57	1.38	2.00	.39x.39	14.85	21.25	16	1-8	
18	450	21.12	4.25	17.25	19.47	16.00	8.27	6.50	4	.81	1.97	2.50	.39x.47	16.85	22.75	16	11/8-7	
20	500	23.25	5.00	19.25	21.59	17.25	8.27	6.50	4	.81	1.97	2.50	.39x.47	18.73	25.00	20	11/8-7	

See chart for Actuator Mounting Flange Drilling.

FLANGE REQUIREMENTS

Skywell are designed for installation between ANSI Class 125/150 lb. weld-neck or slip-on flanges, BS 10 Tables D & E, BS 4504 NP 10/16, DIN ND 10/16, AS 2129 and JIS 10, either flat faced or raised faced. While weld-neck flanges are recommended, Skywell has specifically designed its valve seat to work with slip-on flanges, thus eliminating common failures of other butterfly valve designs. When using raised face flanges be sure to properly align valve and flange. Type C stub-end flanges are not recommended.

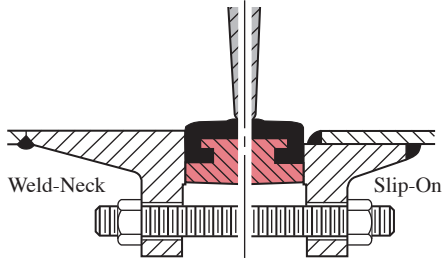

PRESSURE RATINGS*

For bi-directional bubble-tight shut off, disc in closed position:

Inches	mm	psig	bar
2-12	50-300	175	12
14-20	350-500	150	10

For Dead-end Service Applications:

With **downstream flanges installed** or with **vulcanized seats**, the dead-end pressure ratings are equal to valve bi-directional ratings as stated above. With no downstream flanges or with seats that are not vulcanized, the dead-end pressure rating for 2"-12" valves is 75 psi (5 bar) for 14"-20" valves, 50 psi (3.5 bar).

*Pressure Ratings are based on standard disc diameters. For low pressure application, Skywell offers a standard reduced disc diameter to decrease seating torques and to extend seat life, thus increasing the valve's performance and reducing actuator costs for the customer.

VELOCITY LIMITS

For On/Off Services:

Fluids – 30 ft / sec (9m/s)
Gases – 175 ft / sec (54m/s)

C_v VALUE S – VALVE SIZING COEFFICIENT

Valve Size		Disc Position (degrees)								
ins	mm	90°	80°	70°	60°	50°	40°	30°	20°	10°
2	50	144	114	84	61	43	27	16	7	1
2 1/2	65	282	223	163	107	67	43	24	11	1.5
3	80	461	364	267	154	96	61	35	15	2
4	100	841	701	496	274	171	109	62	27	3
5	125	1376	1146	775	428	268	170	98	43	5
6	150	1850	1542	1025	567	354	225	129	56	6
8	200	3316	2842	1862	1081	680	421	241	102	12
10	250	5430	4525	2948	1710	1076	667	382	162	19
12	300	8077	6731	4393	2563	1594	1005	555	235	27
14	350	10538	8874	5939	3384	2149	1320	756	299	34
16	400	13966	11761	7867	4483	2847	1749	1001	397	45
18	450	17214	14496	10065	5736	3643	2237	1281	507	58
20	500	22339	18812	12535	7144	4536	2786	1595	632	72

C_v is defined as the volume of water in U.S.G.P.M. that will flow through a given restriction or valve opening with a pressure drop of one (1) p.s.i. at room temperature. Recommended control angles are between 25°–70° open. Preferred angle for control valve sizing is 60°–65° open.

EXPECTED SEATING/UNSEATING TORQUES (Lb.-Ins.)

Valve Size		Full-Rated Pressure Valves				Reduced Disc Diameter
		Δ P (PSI)				Δ P (PSI)
ins	mm	50	100	150	175	50
2	50	125	130	135	140	125
2 1/2	65	195	205	215	220	195
3	80	260	275	290	297	260
4	100	400	425	450	462	267
5	125	615	670	725	755	410
6	150	783	871	953	1003	537
8	200	1475	1650	1825	1915	983
10	250	2240	2520	2800	2940	1493
12	300	3420	3870	4320	4545	2280
14	350	4950	5700	6450	—	3300
16	400	6400	7700	9000	—	4267
18	450	7850	9850	11850	—	5267
20	500	10300	12900	15500	—	6867

Valve Torque Rating – Skywell has classified valve torque ratings according to 3 types: non-corrosive lubricating service, general service, and severe service. Torques listed above are for general services. Consult Skywell for torque information corresponding to specific applications.

TO USE TORQUE CHART, NOTE THE FOLLOWING:

- 1) For Skywell Series 201, 211, 301, 311 and 341.
- 2) Review Technical Bulletin No. 1001, Expected Seating/Unseating Torques, for explanation of the 3 service classes and their related seating/unseating torque values for given pressure differentials of Full-Rated and Reduced Disc Diameter valves.
- 3) Dynamic Torque values are not considered. See

Technical Bulletin No. 1002 for evaluation of Dynamic Torque values vs. Seating/Unseating Torque values.

- 4) Do not apply a safety factor to above torque values when determining actuator output torque requirement.
- 5) For 3 way assemblies where one valve is opening and other is closing, multiply torque by 1.5 factor.

SPECIFICATIONS

RECOMMENDED SPECIFICATIONS FOR SKYWELL SERIES 301/311 SHALL BE:

- Polyester coated, cast iron, wafer or lug bodies.
- With flange locating holes that meet ANSI Class 125/150 (or BS 10 Tables D & E, BS 4504 NP 10/16, DIN ND 10/16, AS 2129 and JIS 10) drillings.
- Through-stem direct drive double "D" design requiring no disc screws or pins to connect stem to disc with no possible leak paths in disc/stem connection.
- Stem mechanically retained in body neck and no part of stem or body exposed to line media.
- Tongue-and-groove seat design with primary hub seal and a molded O-ring suitable for weld-neck and slip-on flanges. Seat totally encapsulates the body with no flange gaskets required.
- Spherically machined, hand polished disc edge and hub for minimum torque and maximum sealing capability.
- Equipped with non-corrosive bushing and self-adjusting stem seal.
- Bi-directional and tested to 110% of full rating.
- Bi-directional pressure ratings:
2"-12" valves: 175 psi, 14"-20" valves: 150 psi
- Lug bodies for dead end service
With downstream flanges or vulcanized seats, pressure ratings are equal to bi-directional ratings as stated above.
With no downstream flanges or non-vulcanized seats: 2"-12" valves: 75 psi, 14"-20" valves: 50 psi
- No field adjustment necessary to maintain optimum field performance.
- The valve shall be Skywell Series 301 wafer / 311 lug or equal.

WEIGHTS

Valve Size		Series 30	Series 31
ins	mm		
2	50	5.5	7.0
2½	65	7.0	8.0
3	80	7.5	9.0
4	100	11.5	15.0
5	125	14.0	20.0
6	150	17.0	23.0
8	200	34.0	42.0
10	250	49.0	66.0
12	300	67.0	88.0
14	350	95.0	114.0
16	400	135.0	166.0
18	450	200.0	226.0
20	500	260.0	305.0

Weights are in lbs.

MATERIALS SELECTION

2" – 20" (50mm-500mm)

BODY :

- Cast Iron ASTM A126 Class B
- Ductile Iron ASTM A536
- Cast Steel ASTM A216 WCB
- Aluminum ASTM B26

SEAT:

- Buna-N – Food Grade
- EPDM – Food Grade
- FKM*
- White Buna-N – Food Grade

STEM :

- Coated Carbon Steel
- 416 Stainless Steel ASTM A582 Type 416
- 304 Stainless Steel ASTM A276 Type 304
- 316 Stainless Steel ASTM A276 Type 316
- Monel

DISC :

- Aluminum Bronze ASTM B148-954
- Coated Ductile Iron ASTM A536 Gr. 65-45-12
- Ductile Iron, Nylon 11 Coated, ASTM A536 Gr. 65-45-12
- Ductile Iron, Halar Coated, ASTM A536 Gr. 65-45-1 2
- 316 Stainless Steel ASTM A351 CF8M
- Hastelloy C-276 ASTM B575 Alloy N10276

COMPONENTS

No.	Qty.	Description
1	1	Body
2	1	Seat
3	1	Disc
4	1	Stem
5	1	Stem Seal
6	1	Stem Bushing
7	2	Stem Retainer
8	1	Thrust Washer
9	1	Retaining Ring

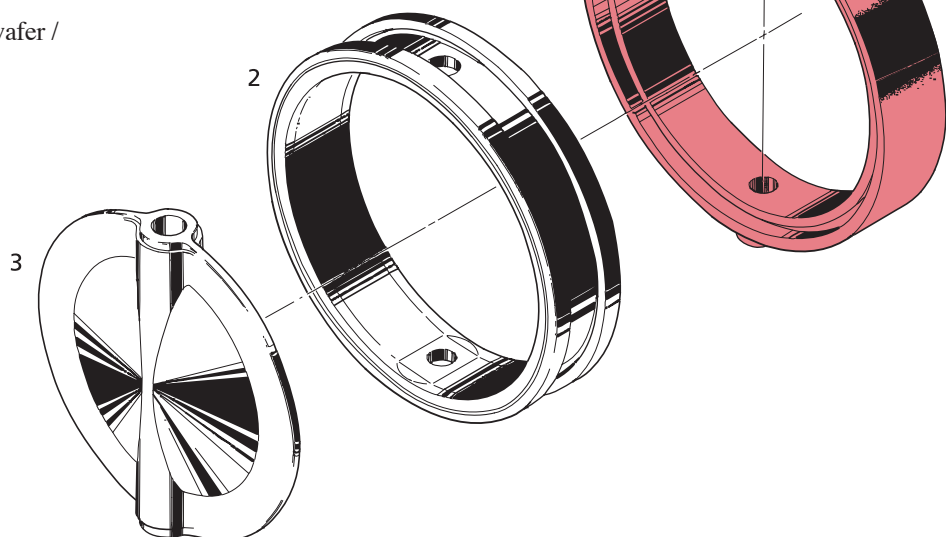

TEMPERATURE RANGE OF SEATS

Type	Maximum	Minimum
EPDM	+250°F(121°C)	-40°F(-40°C)
Buna-N	+212°F(100°C)	0°F(-18°C)
FKM*	+400°F(204°C)	0°F(-18°C)

*FKM is the ASTM D1418 designation for Fluorinated Hydrocarbon Elastomers (also called Fluoroelastomers).

INSTALLATION

Position the disc in the partially open position, maintaining the disc within the body face-to-face. Place the body between the flanges and install flange bolts. **Do not use flange gaskets.**

Before tightening flange bolts, carefully open the disc to the full open position to ensure proper alignment and clearance of the disc O.D. with the adjacent pipe I.D. Leave disc in the full open position and tighten flange bolts per required

specification. Once bolts are tightened, carefully rotate disc to closed position to ensure disc O.D. clearance.

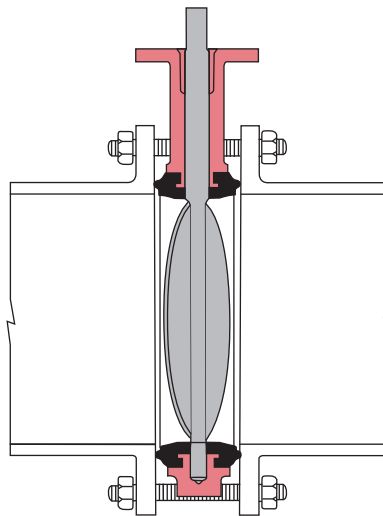

Disc in the Partially Open Position

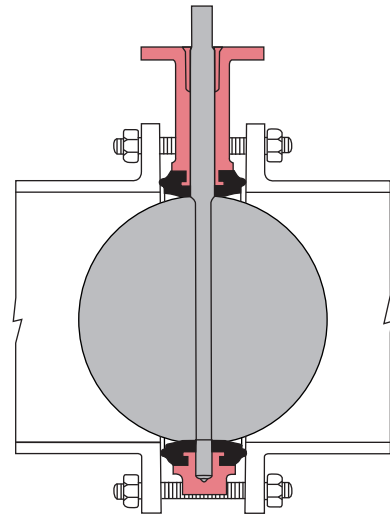

Disc in the Full Open Position

MAINTENANCE AND REPAIR

The many Skywell features minimize wear and maintenance requirements. No routine lubrication is required. All components – stem, disc, seat, bushing, stem seal, etc., are field replaceable, no adjustment is needed. If components require replacement, remove the valve from the line by placing the disc near the closed position, spread the flanges, support the valve, then remove the flange bolts. No valve maintenance, including removal of manual or power actuators, should be performed until the piping system is completely depressurized.

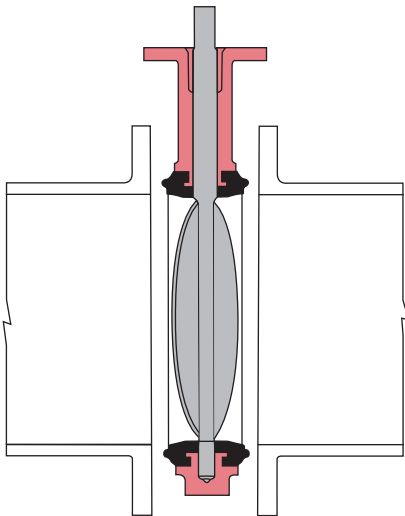

Disc in the Near Closed Position

DISASSEMBLY

Remove the handle, gear operator, or actuator from actuator mounting flange. Remove “Spirolox” retaining ring. Remove stem with its thrust washer and two C-ring stem retainers. Remove bushing and seal. Remove the disc from the seat, protecting disc edge at all times. Push the seat into an oval shape, then remove the seat from the body.

ASSEMBLY

Push the valve seat into an oval and push it into the body with seat stem holes aligned to body stem holes. Push stem into the stem hole of body. For aid in inserting disc, slightly protrude stem beyond the I.D. of the top of the seat. Install a light coating of foodgrade silicone oil (for silicone free applications use soap and water) on the I.D. of seat. Insert the disc into the seat by lining up the disc hole with the stem hole of the seat. Note: the broached double “D” flats

in the disc must be toward the bottom of valve body. (Take special care when lining disc up with stem.) With a downward pressure and rotating the stem back and forth, push the stem until the stem touches the bottom of the body stem hole. Make certain that when pushing the stem through disc bottom, the broached flats of stem and disc are aligned. After the stem has engaged the disc, but before the stem is firmly seated in the body, replace the stem seal and bushing. Install the two C-ring stem retainers in the groove in the stem and thrust washer on top of the C-rings. Seat the stem firmly in the body and install the “Spirolox” retaining ring back into position.

DISTRIBUTOR

All statements, technical information, and recommendations in this bulletin are for general use only. Consult Skywell representatives or factory for the specific requirements and material selection for your intended application. The right to change or modify product design or product without prior notice is reserved.

United States patent number 5,152,501.

Other patents issued and applied for worldwide.

SKYWELL